

Fortress Gate Box Frame Roller



The Fortress Box Frame Roller Gate, manufactured by Tymetal Corp., represents a dramatic breakthrough in the design, construction and performance of large roller gates by using a specially designed wheel system. Openings up to 400 feet have been protected using this design. When the gate is operating under normal load, the wheels run on the flat surfaces of the top and side of a steel beam. As wind begins to put lateral pressure on the gate, the width of the wheel system and its low center of gravity tends to keep the gate in place. However, when the wind load is strong enough to cause the wheels to lift from the beam, the safety guides come in contact with the underside of the top flange of the track and the gate remains safely anchored to the ground.



Box Frame Roller Gates are fabricated from 6063-T6 aluminum alloy extrusions. The primary members (top and bottom) are "P" shaped in cross section. The vertical members alternate between 1" x 2" and 1" x 1" in cross section and are spaced apart at a distance not to exceed the overall height of the box frame. The gate is constructed in "box" form with the width between the frames measuring 24" from outside to outside.

Roller wheel trolley assemblies are bolted to the box frame at pre-specified intervals. Each assembly consists of several steel members which are welded together to provide the support to which the axle is secured. The gate rolls on two parallel tracks which are embedded in concrete so that the top of the track is level with the ground surface.



TC-31 © January 2006

Greenwich, NY
Pearland, TX

A FORT MILLER GROUP COMPANY
WWW.TYMETAL.COM

1-800-328-4283
FAX: 1-518-692-9404

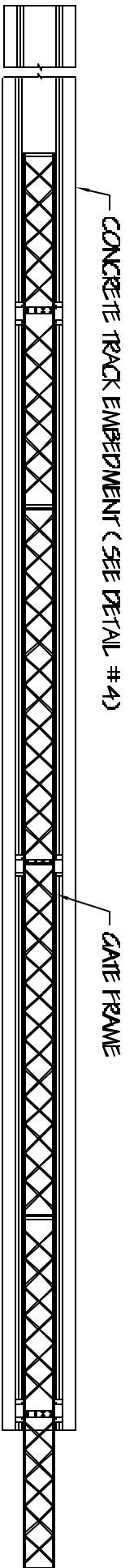

1 PLAN VIEW
 BR1001 Scale: None

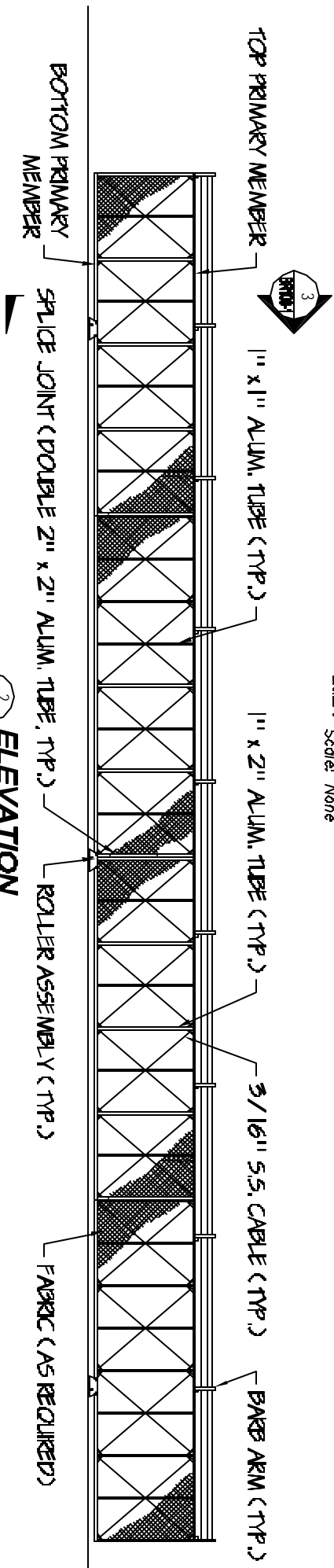

2 ELEVATION
 BR1001 Scale: None

NOTES:

1. EMBEDDED W4 x 13 I-BEAM TRACK SYSTEM PROVIDED BY OTHERS.
2. THE TOTAL NUMBER OF PANELS REQUIRED WILL VARY DEPENDING ON THE OVERALL GATE LENGTH AND WILL BE DETERMINED AS FOLLOWS: DIVIDE THE OVERALL GATE LENGTH BY 48 AND ROUND UP TO THE NEAREST WHOLE NUMBER.
3. CONCRETE FOOTING SHALL BE SIZED AS REQUIRED BY A LOCAL ENGINEER IN ACCORDANCE WITH ALL JOB SPECIFICATIONS.
4. BARB ARMS ARE OPTIONAL.

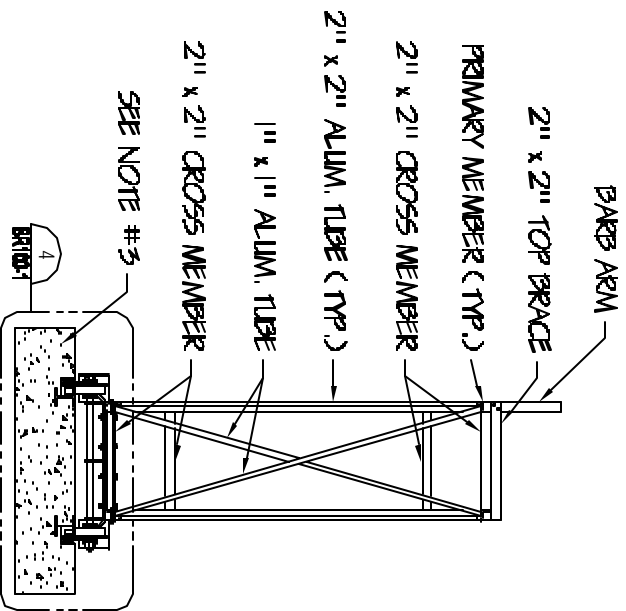

3 ASSEMBLY SECTION
 BR1001 Scale: None

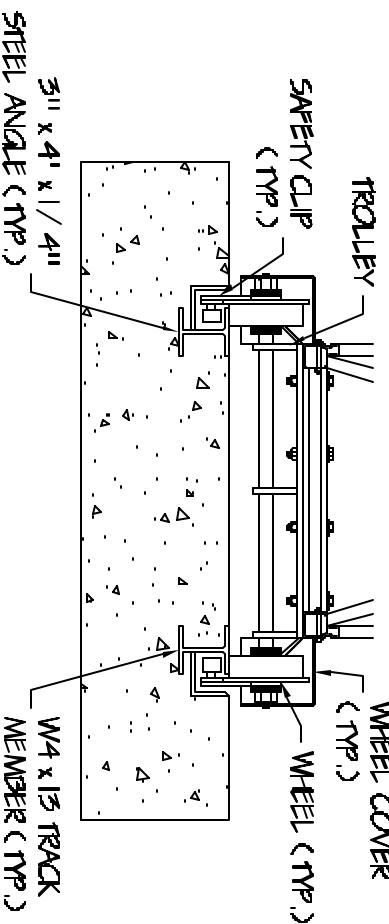

4 TRACK IMBEDMENT SECTION
 BR1001 Scale: None