

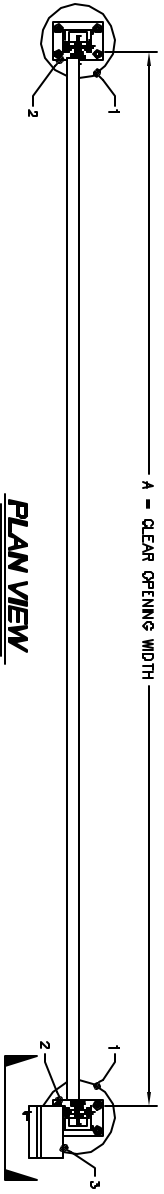

**TYMETAL CORP.**  
www.tymetal.com

2549 STATE ROUTE 40  
GREENWICH, N.Y. 12834  
PH (800) 398-4983 - FX (518) 862-9404



**PLAN VIEW**  
Scale: None

NOTE:  
1. BOTH LIFTING COLUMNS COME COMPLETELY ASSEMBLED FROM THE FACTORY FOR EASE OF INSTALLATION.  
2. BARB ARMS AND BARBED WIRE ARE OPTIONAL.

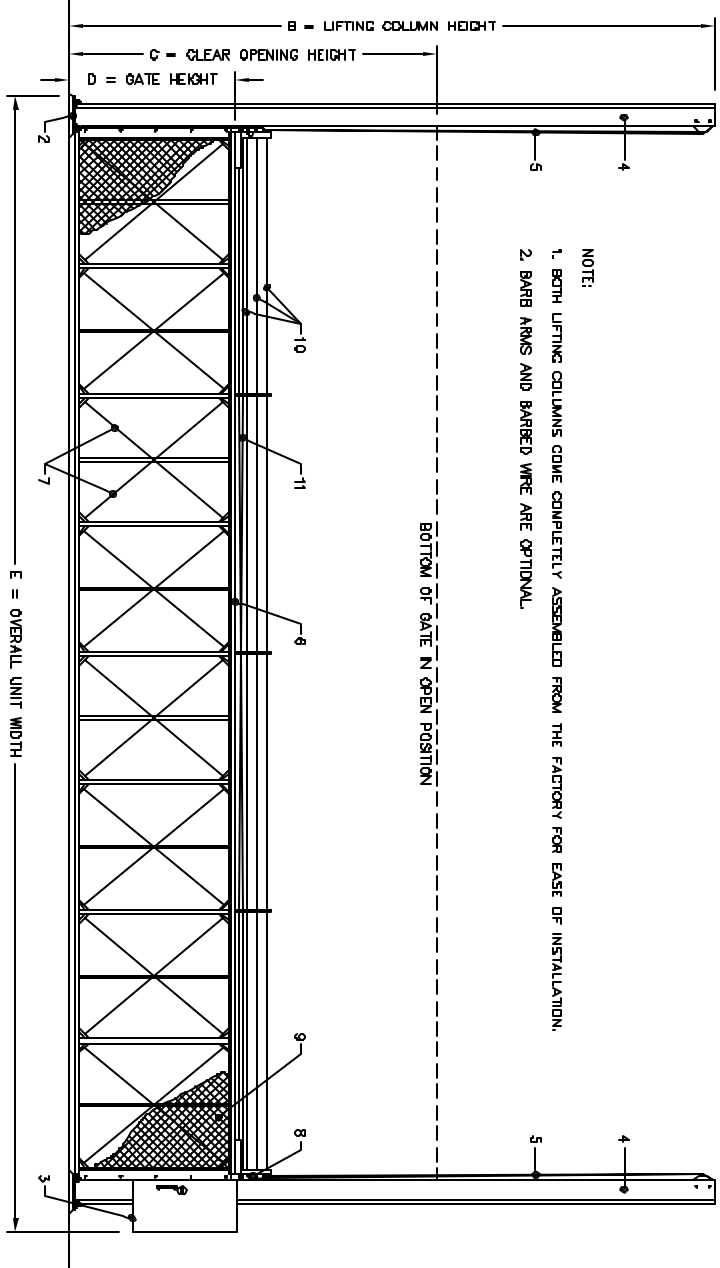

**ELEVATION**  
Scale: None

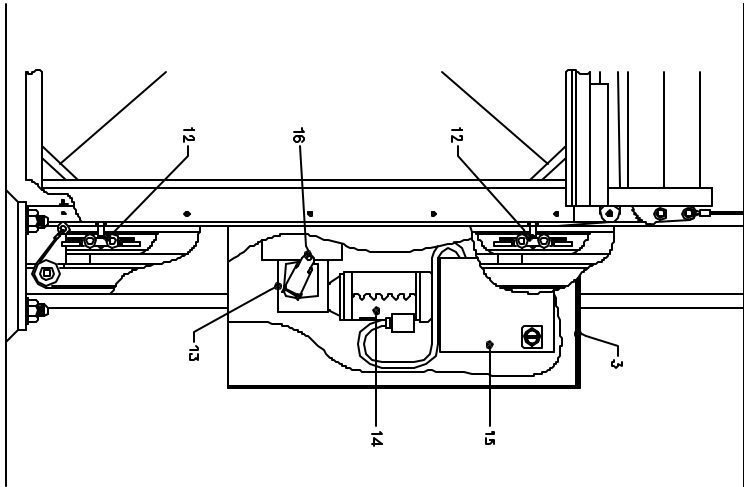

**DRIVE ASSEMBLY**  
Scale: None

**CRITICAL DIMENSION CHART**

MARK	DESCRIPTION	FORMULA	DIMENSION
A	CLEAR OPENING	A	-
B	LIFTING COLUMN HEIGHT	C + D + 4'-0"	-
C	CLEAR OPENING HEIGHT	C	-
D	NOMINAL GATE HEIGHT	D	-
E	OVERALL UNIT WIDTH	A + 2'-11"	-

**VERTICAL LIFT GATE**

**COMPONENT REFERENCES**

MARK	DESCRIPTION	NOTES:	MARK	DESCRIPTION	NOTES:
1	CONCRETE COLUMN FOOTING	PRE-ENGINEERED BY TYMETAL	9	IN FILL MATERIAL	AS REQUIRED BY OWNER
2	LIFTING COLUMN BASE PLATE		10	BARBED WIRE	SEE NOTE #2
3	MOTOR BOX		11	ANTI-RACKING CABLES	2 REQUIRED
4	W/12x53 LIFTING COLUMN	SEE NOTE #1	12	W/4 TRUCK ASSEMBLY	4 REQUIRED
5	PRIMARY LIFTING CABLE	TYP. AT ENDS OF GATE FRAME	13	GEARBOX	
6	TOP PRIMARY MEMBER		14	MOTOR	
7	3/16" S.S. CABLE		15	CONTROLLER	
8	SAFETY CAM		16	CRANK HANDLE	FOR MANUAL OPERATION