

1 PLAN VIEW
 GS184-1R Scale: None

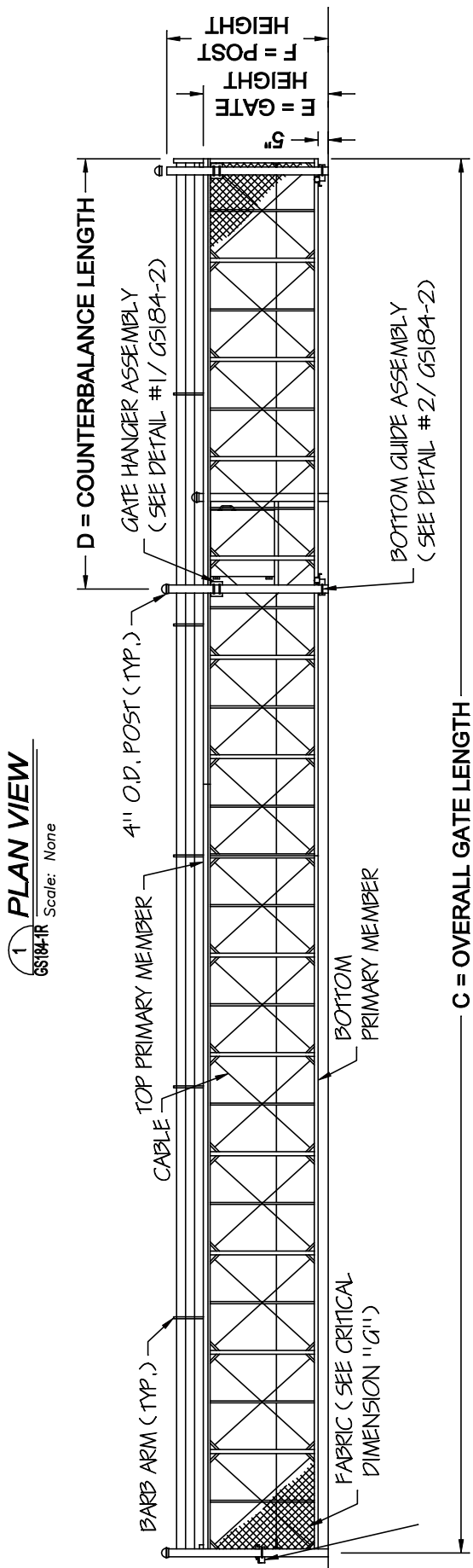

2 ELEVATION
 GS184-1R Scale: None

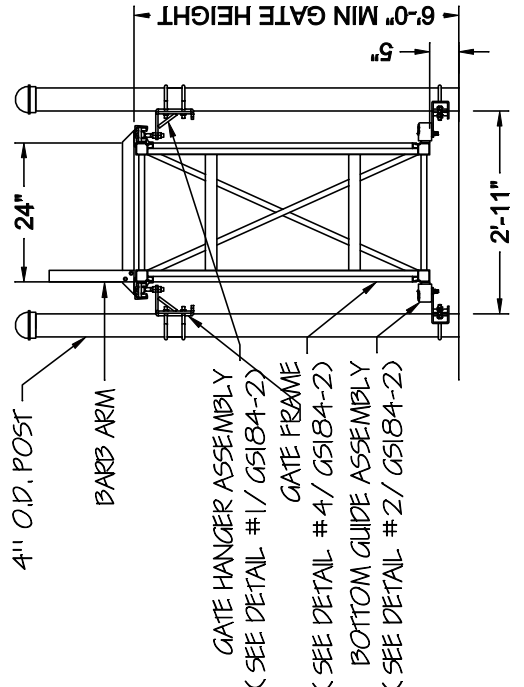

3 ASSEMBLY SECTION
 GS184-1R Scale: None

- NOTES:
 1. ALL FITTINGS PROVIDED FOR 4" O.D. POSTS. OTHER SIZES AVAILABLE UPON REQUEST.
 2. BARB ARMS ARE OPTIONAL.
 3. GATE ELEVATION IS VIEWED FROM THE OUTSIDE OF THE SECURE AREA LOOKING IN.

CRITICAL DIMENSION CHART	
A	CLEAR OPENING
B	COUNTERBALANCE POST SPACING C/C
C	OVERALL GATE LENGTH
D	COUNTERBALANCE LENGTH
E	NOMINAL GATE HEIGHT
F	POST HEIGHT
G	FABRIC HEIGHT

A	A
B	(A/2) - 11"
C	A x 1.5
D	A x 0.5
E	E
F	E + 1'-6"
G	E - 12"

REVISION LEVEL: R0	DATE: 1/30/16	DATE: 1/30/16
As Noted	CHECKED BY: BGG	DRAWN BY: NJD
SCALE:		

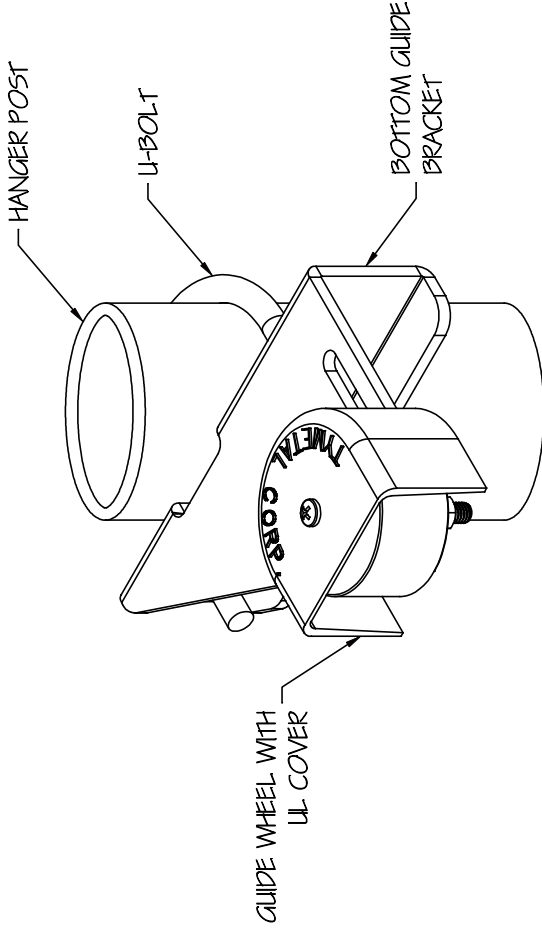

2 BOTTOM GUIDE ASSEMBLY

Scale: None

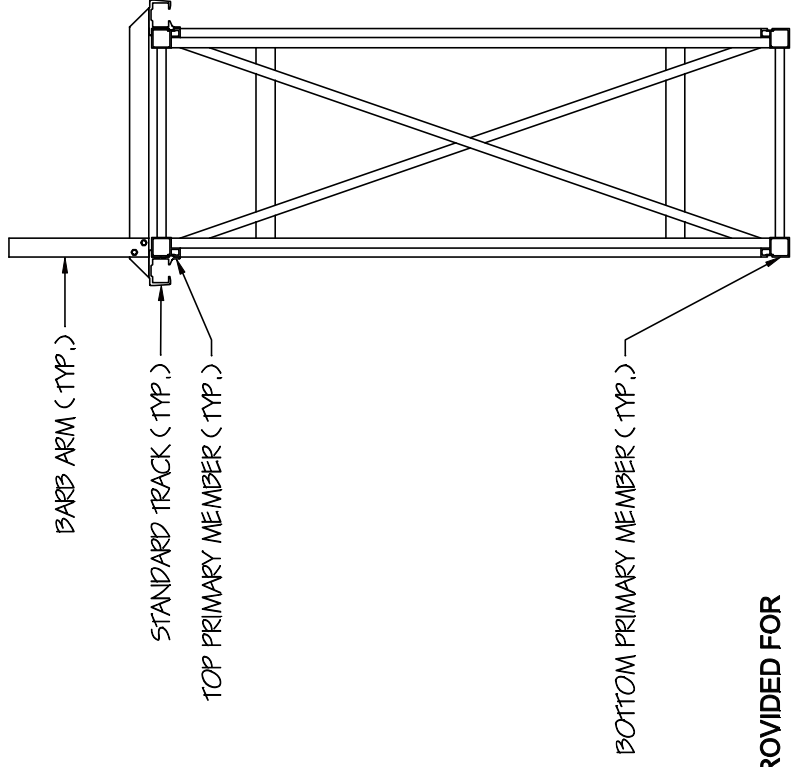

4 GATE FRAME SECTION

Scale: None

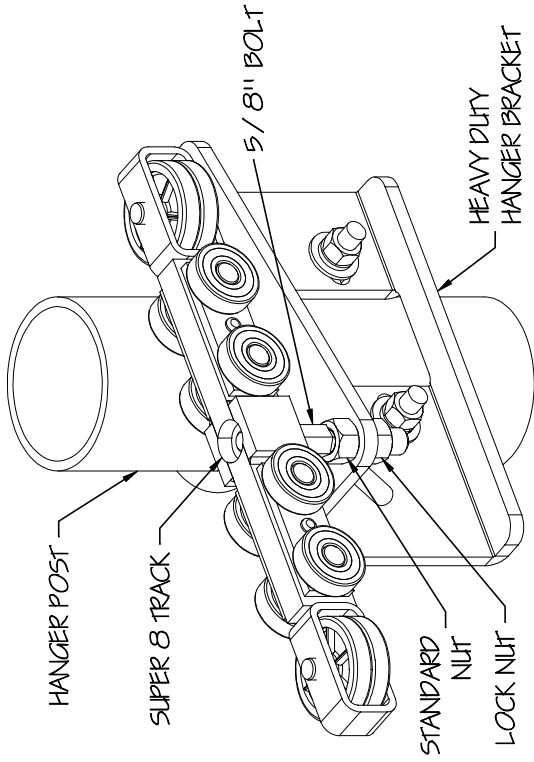

NOTE: SUPER 8 TRUCK SHOWN. W4 TRUCKS MAY BE USED FOR LIGHTER GATES.

1 GATE HANGER ASSEMBLY

Scale: None

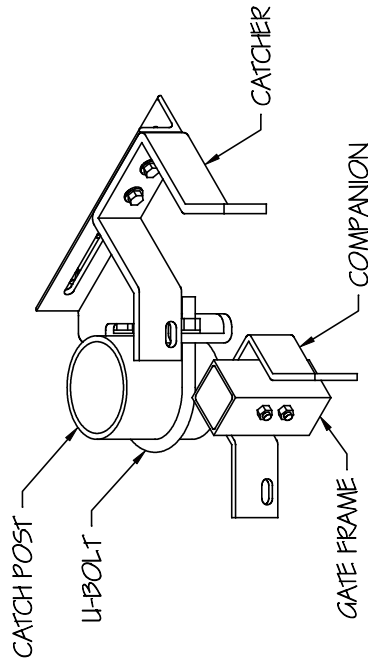

3 CATCH ASSEMBLY

Scale: None

NOTES:
 1. ALL FITTINGS PROVIDED FOR 4" O.D. POSTS. OTHER SIZES AVAILABLE UPON REQUEST.

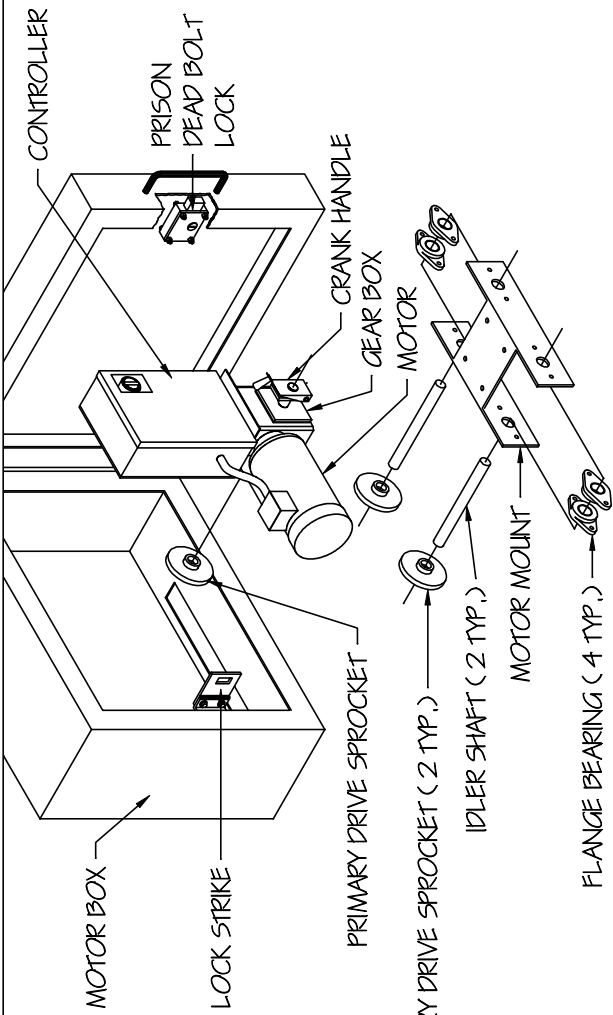

2 OPERATOR DRIVE ASSEMBLY
 Scale: None

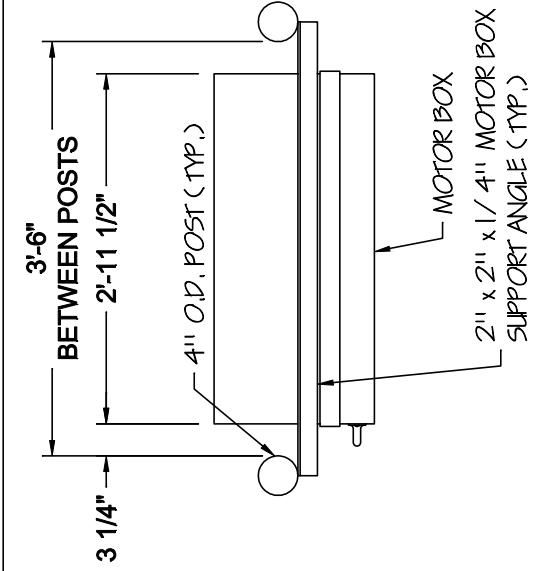

1 OPERATOR PLAN
 Scale: None

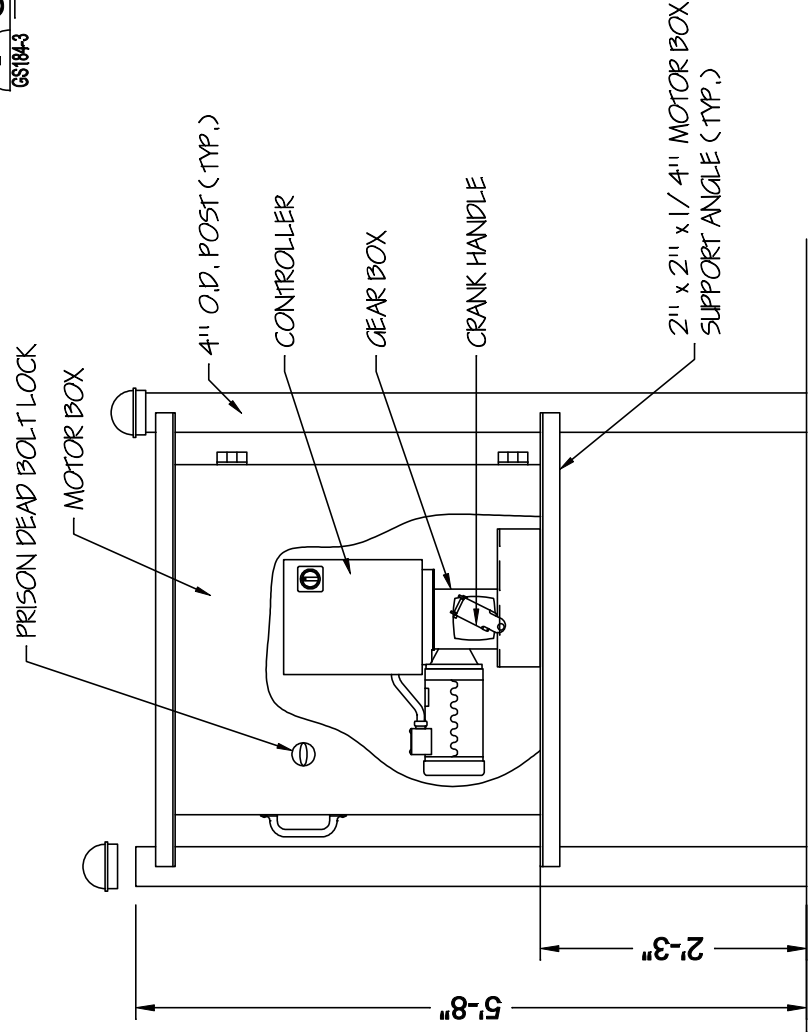

3 OPERATOR FRONT ELEVATION
 Scale: None

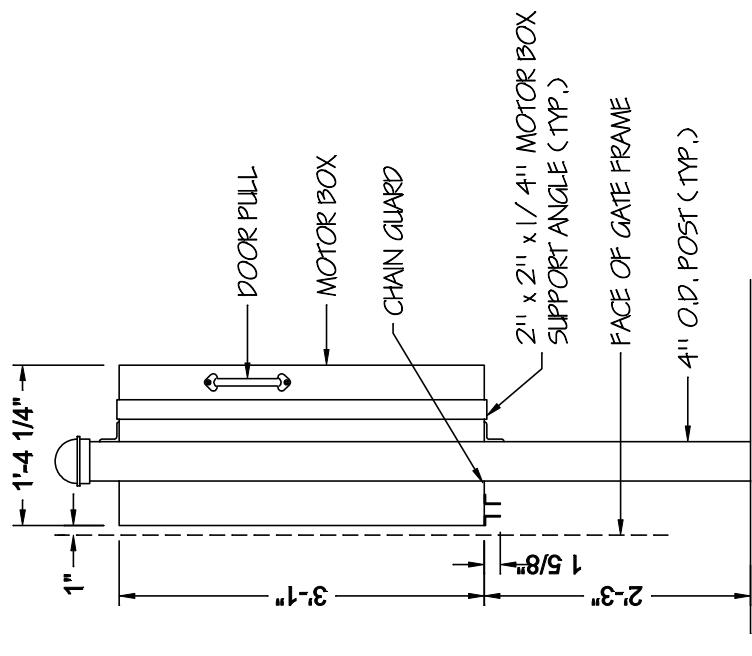

4 OPERATOR SIDE ELEVATION
 Scale: None