

1 **PLAN VIEW**  
PL-40-003-1 Scale: None

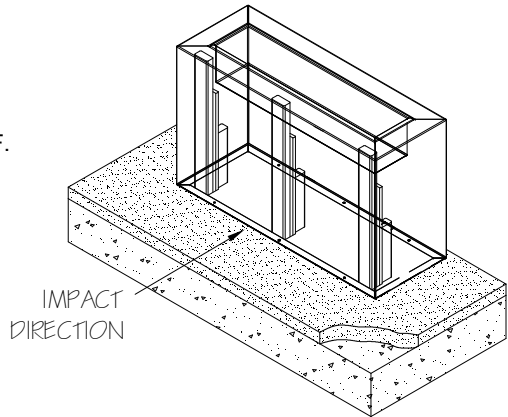

4 **ISOMETRIC VIEW**  
PL-40-003-1 Scale: None

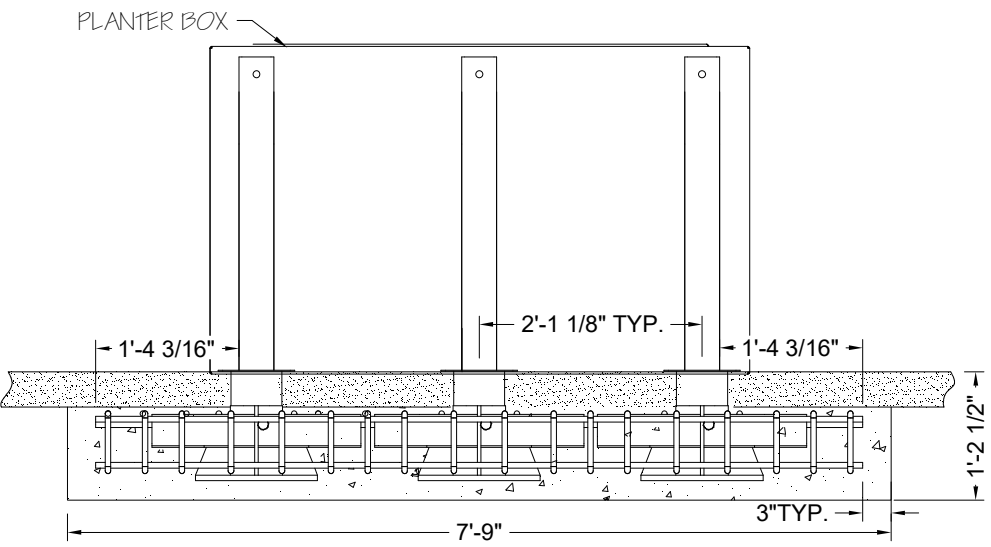

2 **FRONT VIEW**  
PL-40-003-1 Scale: None

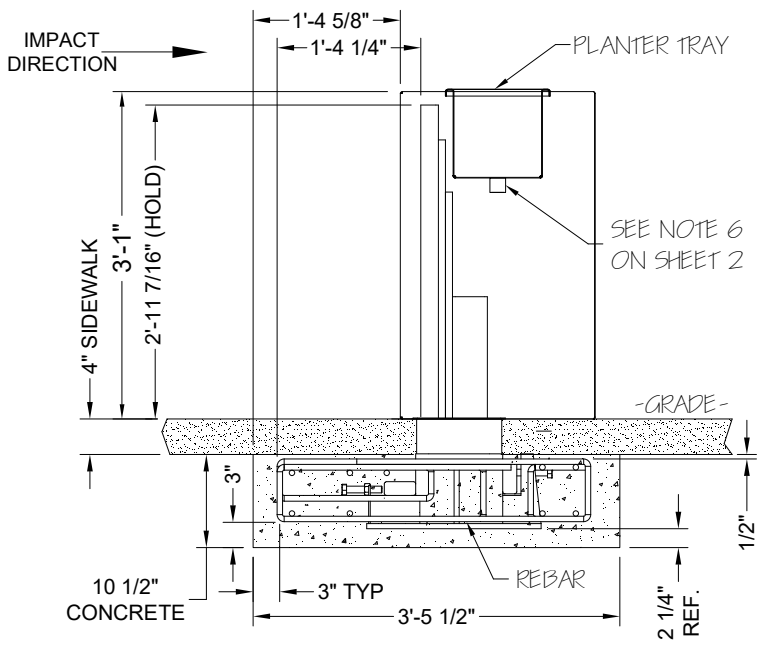

3 **SIDE VIEW**  
PL-40-003-1 Scale: None

<b>PROPRIETARY &amp; CONFIDENTIAL</b> The information contained in this drawing is the sole property of TYMETAL CORP. Any reproduction in part or as a whole without the written permission of TYMETAL CORP. is prohibited. www.tymetal.com 678 Wilbur Ave. GREENWICH, N.Y. 12834 PH: (800) 328-4283 - FX: (518) 692-9404	DRAWN BY: JDJ DATE: 11/6/18 CHECKED BY: BGG DATE: 11/6/18 SCALE: As Noted REVISION LEVEL: R1	PROJECT: Planter 40 + 100 Removeable Bollards With Sidewalk SUBJECT: Planter 40 + 100 Removeable Bollards With Sidewalk CONTRACTOR:	DIRECTORY/CAD FILE: PL-40-003 Planter 40 Removeable R1 SHEET NUMBER: 1 of 2 DRAWING NUMBER: PL-40-003-1
	ARCHITECT/ENGINEER:		

PRELIMINARY DRAWING - NOT FOR CONSTRUCTION

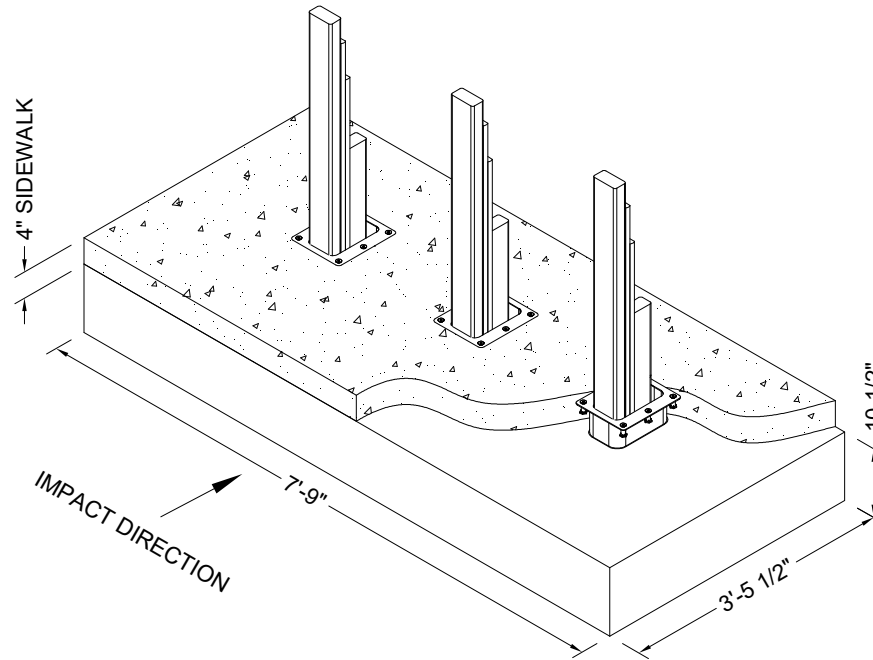

**1 INSTALL DRAWING**  
 PL-40-003-2 Scale: None

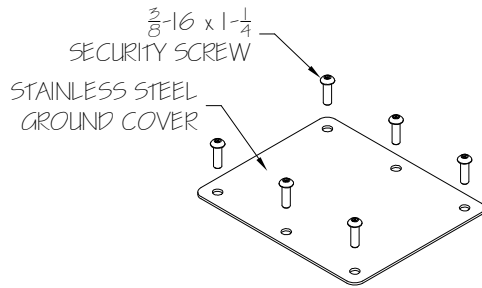

**2 BOLLARD GROUND COVER**  
 PL-40-003-2 Scale: None

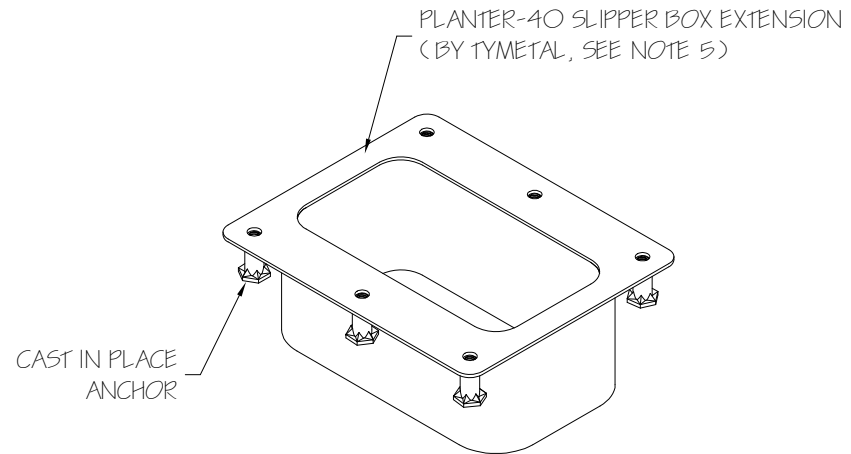

**3 ISOMETRIC VIEW OF SLIPPER BOX EXT.**  
 PL-40-003-2 Scale: None

- NOTES:
1. COPY AND DESIGN RIGHT BELONG TO SAFETYFLEX.
  2. TESTED TO BSI PAS 68:2010. SIMILAR TO U.S. DOS K-8 AND ASTM F2656-07 M40. TESTED FOOTING WAS 39 3/8" WIDE x 90 1/2" LONG x 7 7/8" DEEP.
  3. BOLLARD IS REMOVABLE IN THIS INSTALLATION.
  4. USE 6000 PSI CONCRETE FOR BOLLARD FOOTING.
  5. PLACE SLIPPER BOX EXTENSION BEFORE POURING BOLLARD FOOTING.
  6. DRAINAGE TO BE FURNISHED & INSTALLED BY INSTALLATION CONTRACTOR.

**PRELIMINARY DRAWING - NOT FOR CONSTRUCTION**

<b>PROPRIETARY &amp; CONFIDENTIAL</b> The information contained in this drawing is the sole property of TYMETAL CORP. Any reproduction in part or as a whole without the written permission of TYMETAL CORP. is prohibited.	DRAWN BY: JDJ DATE: 11/6/18	PROJECT: PL-40-003 Planter 40 Removable RI	DIRECTORY/CAD FILE: PL-40-003 Planter 40 Removable RI
	CHECKED BY: BGG DATE: 11/6/18	SUBJECT: Planter 40 + 100 Removable Bollards With Sidewalk	SHEET NUMBER: 2 of 2
	SCALE: As Noted REVISION LEVEL: R1	CONTRACTOR:  ARCHITECT/ENGINEER:	DRAWING NUMBER: <b>PL-40-003-2</b>

**TYMETAL CORP.**  
 www.tymetal.com  
 678 Wilbur Ave.  
 GREENWICH, N.Y. 12834  
 PH: (800) 328-4283 - FX: (518) 692-9404