

Fortress Box Frame Cantilever Slide Gate

Spans single clear opening widths up to 60 feet and double/bi-parting openings up to 120 feet.

FEATURES:



Design:

Requires no overhead track, ground track or ground wheels.



Construction:

Welded aluminum using custom heavy wall extrusions.



Durable:

Fabricated by AWS Certified Welders.



Dual Track, Box Frame System:

Dual enclosed tracks with trussed framework and ball bearing truck systems suited for all weather conditions.



Diagonal Cables:

Adjustable 1/4" galvanized steel cables provide zero to minimal deflection.



Tested:

Cycle tested; performs reliably over time.

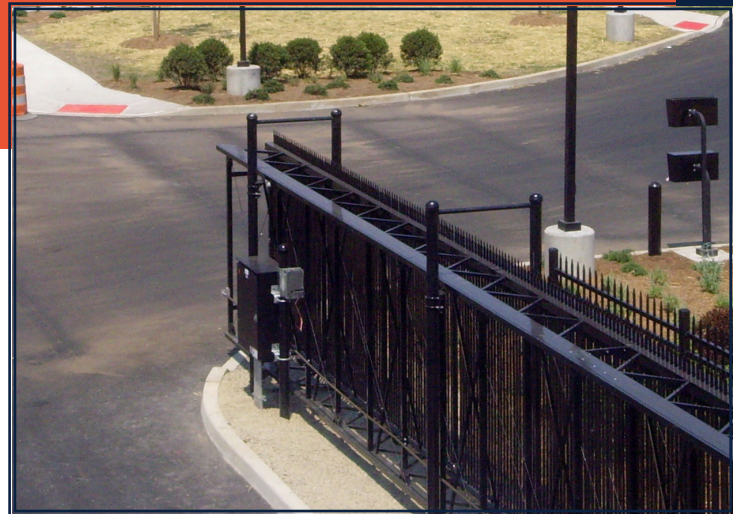

Available with fully integrated operator.

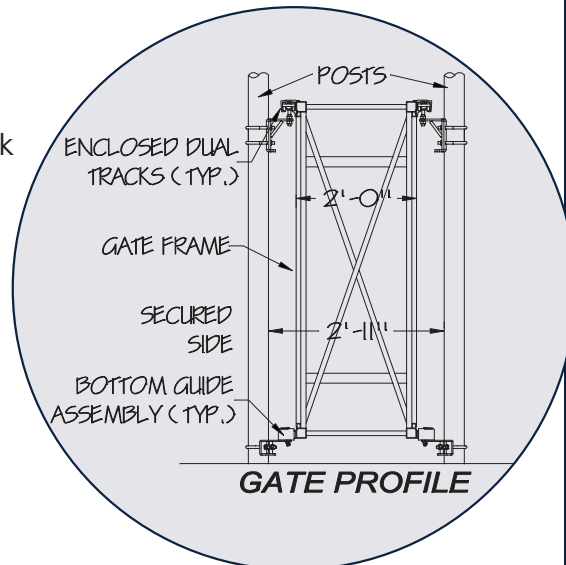

Visit Our Website for a Full Specification and Drawings

Fortress Box Frame Cantilever Slide Gate

Maximum Clear Opening Width	Single gate: 60 feet; Double/Bi-parting gates: 120 feet
Maximum Clear Opening Height	Standard Height: Up to 8 feet (Note: Contact manufacturer regarding sizes greater than those listed.)
Gate Construction	<ul style="list-style-type: none"> ▶ Trussed box frame with dual track design, supported by four posts. ▶ Gate track systems will be keyed to interlock into the primary upper horizontal gate frame member and then welded to form a composite structure. ▶ The gate frame counterbalance length will be a minimum of 50% of the clear opening width. ▶ Intermediate vertical members of the gate frame to be spaced less than 50% of the gate frame height. ▶ The gate frame includes two adjustable diagonal ¼" galvanized steel cables per bay for stability and to allow complete gate frame adjustment.
Safety	Meets ASTM F 1184 Type II, Class 2; if automated meets UL 325 and ASTM F 2200.
Infill Options	<ul style="list-style-type: none"> ▶ Aluminized or galvanized steel 2" x 2" x 9-gauge fabric. ▶ 1" x 1" aluminum pickets – each welded in place. ▶ 1" x 1" extended smashed point pickets – punched through top member and welded in place. ▶ High security Anti-Climb welded wire mesh ½" x 3" x 8 gauge galvanized steel. Other welded wire mesh designs available. ▶ Custom horizontal or vertical louvers to block visibility. ▶ Perforated or expanded metal sheets. ▶ Ballistic rated panels. ▶ Custom infills – contact a Tymetal Specification Team member.
Finish	<ul style="list-style-type: none"> ▶ Mill finish aluminum or color/powder coating with polyester powder to color of choice (reference RAL color chart). ▶ If a galvanized steel component (such as infill and posts) color/powder coating is available.
Warranty	<ul style="list-style-type: none"> ▶ The Box Frame Cantilever Slide Gate is warranted against manufacturing defects by the manufacturer for a period of one year from date of sale. The truck assemblies are warranted against manufacturing defects for a period of five years from date of sale. ▶ If a Box Frame Cantilever Slide Gate and Gate Operator are purchased from Tymetal at the same time, both the gate and gate operator will be warranted for a period of three years from date of sale.

Speak with Specifications & Design Support Directly

Contact TYMETAL at 1-800-328-GATE (4283) or gates@tymetal.com

Standard and Custom Solutions, Manufactured in New York and Texas.

678 Wilbur Avenue, Greenwich, NY 12834
4501 Dixie Farm Road, Pearland, TX 77581

VG_Fortress_Box_Frame_CS_06/05/2025

